

1. Scope:

This specification is applicable to Pairdeer battery, R03 Super Heavy Duty (PVC/Foil Jacket), distributed by ZHONGYIN (NINGBO) BATTERY CO., LTD.

2. Law & Regulation Compliances:

This product complies with EU's battery directive (2013/56/EU).

Packaging materials comply with EU's directive on packaging materials and waste (94/62/EC)

3. General:

3.1 Type designation

IEC/JIS R03

3.2 Chemical system: $Zn/NH_4Cl-ZnCl_2-H_2O/MnO_2$

3.3 Nominal voltage: 1.5 V

3.4 Weight: Approximate 7.3 g

3.5 Dimension (mm)

/	min	max
Φ	9.8	10.5
A	43.5	44.5
C	4.3	-
F	-	3.8
G	0.8	-

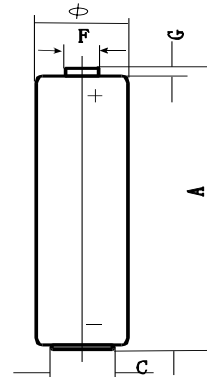

3.6 Heavy Metal Contents:

Hg	Cd	Pb
$\leq 1\text{ppm}$	$\leq 20\text{ppm}$	$\leq 1000\text{ppm}$

3.7 Capacity: Approximate 320mAh (50mA, 1h/12h, 24h/d, $20\pm 2^\circ\text{C}$, e.v.= 0.9V)

3.8

Operation temperature : $-18^\circ\text{C} \sim 35^\circ\text{C}$ Recommend storage temperature : Not exceed 35°C



4. Appearance

The battery visually inspected by unaided eye 30cm away from battery. The battery shall be free from dents, scratch, rust and extruded internal compounds, such as sealing compounds and etc, and serious displacement of artwork. Appearance defects shall not be observed that may adversely affect actual use or performance of batteries.

5. Electrical Characteristics

Unless otherwise stated, all measurements are to be performed at a **Standard Environment** of

20 ± 2°C
55 ± 20% RH.

All samples are normalized for 8 hours at least at the above environment prior to measurement. The digital voltmeter (DCM) is with the precision of 1mV (internal resistance not less than 1 Megohm). The load resistance of the total circuit is accurate within ±0.5% of the specified value.

5.1 Open circuit voltage and closed circuit voltage (Load resistance 3.9Ω, 0.3S)

/	OCV(V)	CCV(V)
Initial	≥1.58	≥1.40

5.2 Service output

Load	3.9Ω	5.1Ω	24Ω	5.1Ω	50mA	75Ω	10Ω	
Test mode	24h/d	4m/h,8h/d	15s/m,8h/d	1h/d	1h/12h,24h/d	4h/d	1h/d	
End voltage	0.9V	0.9V	1.0V	0.8V	0.9V	0.9V	0.9V	
Unit	m	m	h	m	h	h	m	
Applications	Reference	Portable lighting	Remote control	Toy	Digital Audio	Radio/Clock	Digital audio	
Initial	MAD	36	88	7.3	70	6.5	26	170
	Normal	40	98	8.2	85	7.5	26.7	185

m: minute h: hour d: day

Remark: 1) The initial discharge test shall commence within 30 days of manufacture. During stored period, the Batteries shall be stored under 20±2°C , RH 55±20% conditions.

2) Lot release service output test is conducted by 3.9Ω continuous discharging to 0.9 volts.

3) MAD: minimum average duration--our guarantee discharge value.

4)Normal: normal data, it's our normal daily value, battereis dicharge value are on this as base to be upper or lower.

6. Leakage Resistance

Over discharge leakage test

Test conditions: 20±2°C, RH 55±20%, 3.9Ω continuous discharge to 0.60V.

Number of test samples: 9 batteries

Requirement: no visible leakage.

7. Safety Characteristics

7.1 User Drop Test

This test simulates the situation when a battery is accidentally dropped.

Test conditions: Undischarged test batteries shall be dropped from a height of 1 m onto a concrete surface. Each test battery shall be dropped six times, twice in each of the three axes. The test batteries shall be stored for 1 h afterwards.

Number of test samples: 5 batteries

Requirement: No fire, No explosion.

7.2 Short-circuit explosion-proof characteristics

This test simulates an external short circuit of a battery during daily handling of batteries.

Test conditions: Positive and negative terminals of an undischarged battery shall be connected directly. The circuit shall be completed for 24 h or until the battery case temperature has returned to ambient. The resistance of the inter-connecting circuitry shall not exceed 0,1 Ω.

Number of test samples: 5 batteries

Requirement: No fire or explosion; Leakage is allowable.

8. Expiry Date:

36 months

9. Expiry Date Marking:

9.1 Unless otherwise specified, each battery will carry a manufacturing date code followed by month and year of manufacturing for domestic and manufacturing date code followed by month and year of expiry for export. (Shelf life 36 months)

10. Packaging Requirements

10.1 It is recommended that packaging for shipment and sales according with Packaging Specification of Pairdeer batteries. For example, 2pcs batteries in a shrink, 20 shrinks in a display box, and 5*2*3 display boxes in a final outer carton , and 5*3*7 outer cartons on a pallet. Flow chart as next page:

10.2 Otherwise packaging for shipment and sales shall conform to the mutually agreed to Packaging Specification of the designated customers.

1

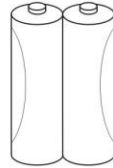

2pcs-shrink(PVC or PET)

2

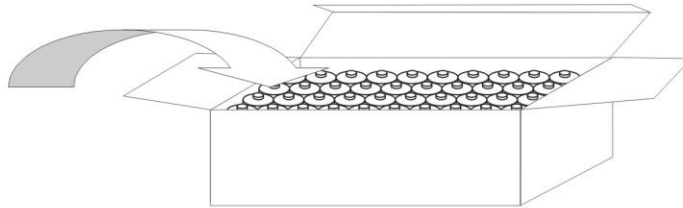

4x10 pcs in a display box

3

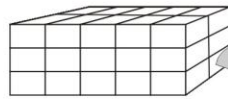

5x2x3 display boxes

plastic bag

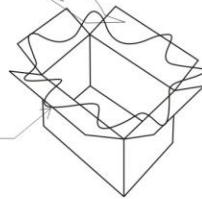

outer carton

4

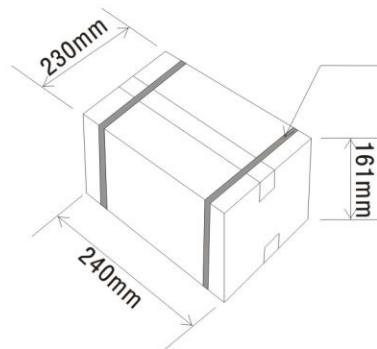

bandage

Gross weight: about 10.2kg

5

PE film bandage

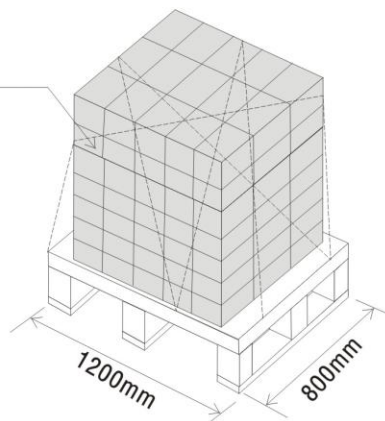

(5x3x7) outer boxes



11. Precautions in Handling of Batteries:

- 11.1 Do not disassemble or short-circuit batteries.
- 11.2 Do not recharge batteries.
- 11.3 Do not dispose of batteries in fire.
- 11.4 Do not allow metal objects to contact the battery terminals.
- 11.5 Do not mix with used or other battery type (such as alkaline with carbon zinc).
- 11.6 Do not solder the batteries directly. If soldering or welding connection to the battery is required, consult our engineer for proper methods.
- 11.7 Do not over-discharge batteries. Force discharging batteries by external power source in a series may cause explosion.
- 11.8 To install or remove batteries, follow the equipment manufacturer's instructions.
- 11.9 Keep battery away from small children. If swallowed, consult a physician at once.
- 11.10 Remove batteries from device when it is not in use.

12. Storage

- 12.1 Store in cool, dry place before use.
- 12.2 It is recommended that the storage temperature be lower than 35°C.
- 12.3 Do not keep batteries at relative humidity of 70% or above for long time.